



Superior Stamper Uniformity

Experience advanced large-scale plating with our dual-position plating unit. Each position is equipped with its own rotating cathode shaft and digitally controlled rectifier. The PLC controller offers user-friendly operation and seamless Industry 4.0 integration.

FEATURES

- Rigid design in stainless steel, polypropylene and titanium
- Titanium anode basket
- Plating vat exhaust function
- Adjustable anode-to-cathode distance
- Dual 20-inch filter housings
- PLC controlled

- Network connection for remote access
- User-friendly touch HMI with programmable speed dial buttons.

OPTIONS

- Flow meter
- Automatic lid opening
- Selective cleaning.

INNOVATIVE AND USER-FRIENDLY ELECTROFORMING SOLUTIONS

Discover the ultimate in electroforming technology with Pheenix Alpha - your go-to choice for stamper production and electroforming solutions. Our system boasts an intelligent and intuitive design that sets it apart in the market. Equipped with a powerful new processor, it adapts to your specific needs with customizable software options.

Pheenix Alpha offers features that empower operators to maintain peak productivity and ensure top-notch quality. Real-time process monitoring provides timely alerts for cartridge replacements, nickel pellet replenishment, and anode basket cleaning. Experience consistent, high-quality production with minimal downtime.

Our system is controlled by an industrial-grade PLC for unmatched reliability. Enjoy user-programmable recipes with exceptional repeatability.

With all components neatly contained within its footprint, our cabinet provides location flexibility, ensuring a seamless fit into your workspace.

Pheenix Alpha's dedicated technicians bring expertise and experience to the table, from development and manufacturing to servicing electroforming systems. We're the world's only manufacturer offering both electroforming and replication systems. Experience the convenience of a one-stop shopping concept for lacquer and DMM family development.

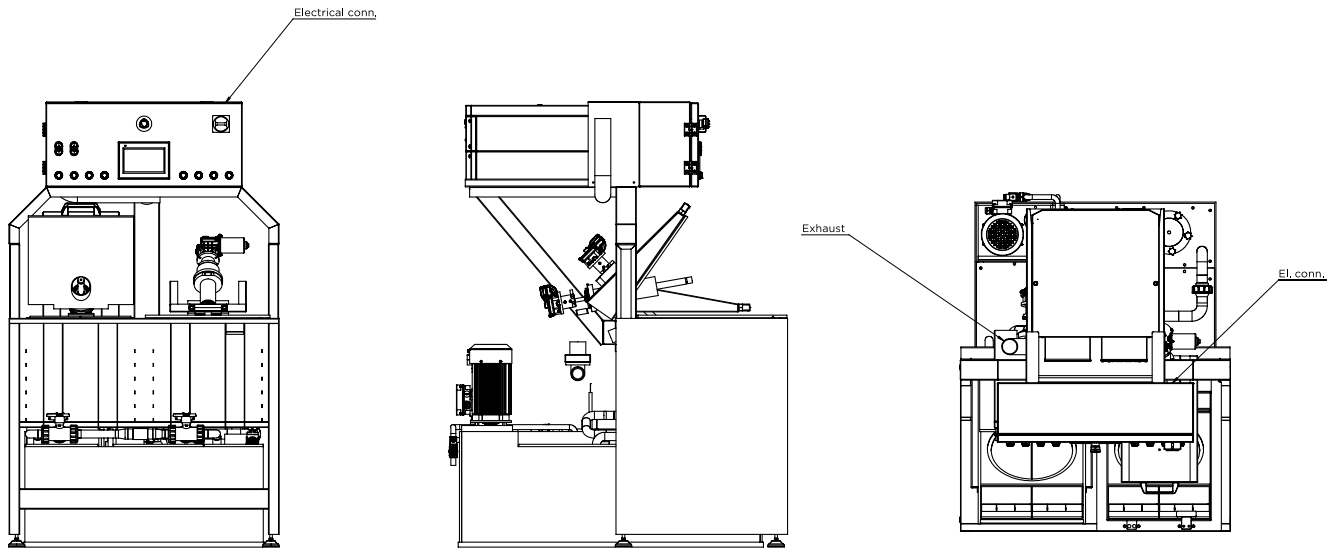

Media Supply requirements for one Pheenix Dual Plating Unit

DIMENSIONS	W 1070 mm × D 1350 mm × H 1800 mm
ELECTRICAL INPUT	400 VAC +/- 5%, 50-60Hz, 3-Phase, 16 Amp, 3P+N+E
EXHAUST CONNECTION	Ø 63 mm
COOLING WATER	12-20°C
TANK	
VOLUME	385 liters
PUMP CAPACITY	10m ³ /h
HEATER	4,5 kW
TITANIUM WATER COOLING COIL	
FILTERS	2 × 20 inches
SERVICE ACCESS BEHIND TANK	Minimum 500 mm
CELL	
VOLUME	40 liters/cell
ROTATION SPEED	45 RPM
ANODE TITANIUM BASKET	2 × Cell, capacity 30 kg/basket
MAX. MEDIA DIAMETER	355 mm
PLATING POWER	
MAX. VOLTAGE	20 VDC
MAX. CURRENT	200 Amps/cell
CONTROL	
PLC AND 7 INCH TOUCH SCREEN	

Please contact us with any questions or to request.

THE INFORMATION PROVIDED MIGHT BE SUBJECT TO CHANGES.



Pheenix Alpha AB
 Skepptuna Borgen 299
 SE 195 93 Märsta
 +46 (0)8 598 933 00
www.pheenixalpha.com

E-mail info@pheenixalpha.com
Spareparts order handling
order@pheenixalpha.com
Helpdesk/support
helpdesk@pheenixalpha.com

