



Efficient Pre-Plating with Advanced Control

Load up to four masters, each controllable individually, for high efficiency. Enjoy the user-friendly interface of the advanced PLC controller, complete with network connectivity and remote access.

FEATURES

- Rigid design in stainless steel, polypropylene, and titanium
- Titanium anode basket
- Plating vat exhaust function
- Adjustable flow
- Dual 20-inch filter housings
- Individual cathode movement for each position
- High output capacity
- Integrated dummy plating function
- PID-regulated temperature control
- PLC control system
- Network connection for remote access
- User friendly detachable HMI touch screen

INNOVATIVE AND USER-FRIENDLY ELECTROFORMING SOLUTIONS

Discover the ultimate in electroforming technology with Phoenix Alpha - your go-to choice for stamper production and electroforming solutions. Our system boasts an intelligent and intuitive design that sets it apart in the market. Equipped with a powerful new processor, it adapts to your specific needs with customizable software options.

Phoenix Alpha offers features that empower operators to maintain peak productivity and ensure top-notch quality. Real-time process monitoring provides timely alerts for cartridge replacements, nickel pellet replenishment, and anode basket cleaning. Experience consistent, high-quality production with minimal downtime.

Our system is controlled by an industrial-grade PLC for unmatched reliability. Enjoy user-programmable recipes with exceptional repeatability.

With all components neatly contained within its footprint, our cabinet provides location flexibility, ensuring a seamless fit into your workspace.

Phoenix Alpha's dedicated technicians bring expertise and experience to the table, from development and manufacturing to servicing electroforming systems. We're the world's only manufacturer offering both electroforming and replication systems. Experience the convenience of a one-stop shopping concept for lacquer and DMM family development.

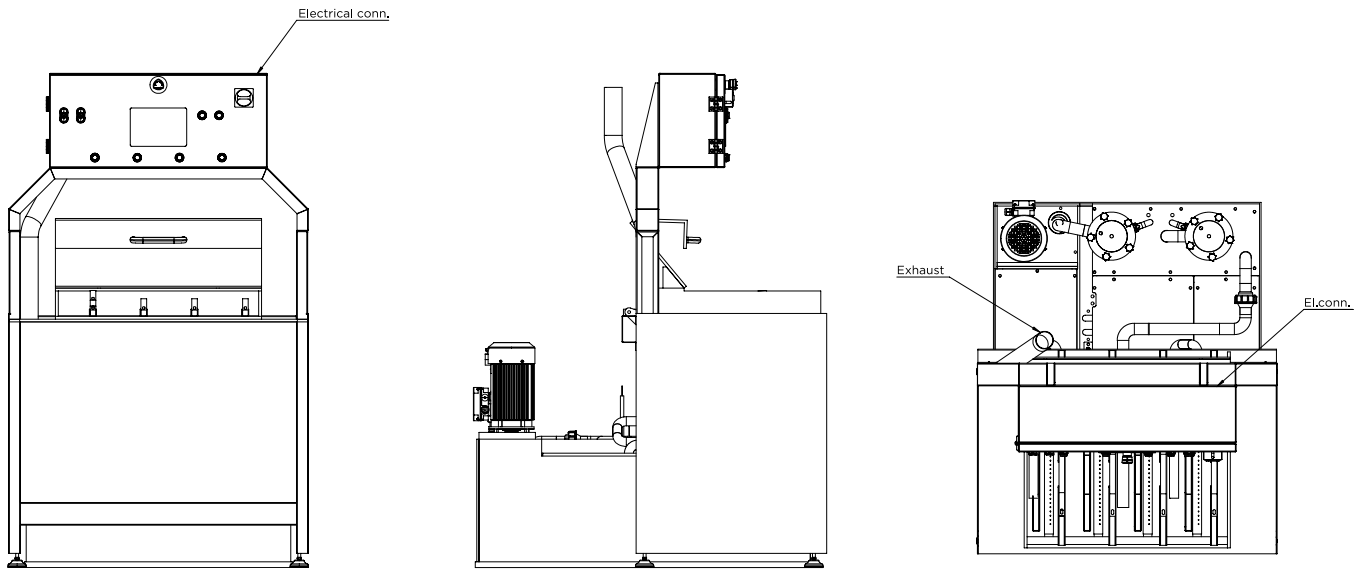

Media supply requirements for one Pheenix Pre-Plating Unit

DIMENSIONS	W 1062 mm X D 1245 mm X H 1750 mm
ELECTRICAL INPUT	400/480 VAC +/- 5%, 50-60Hz, 3-Phase, 16 Amp, 3P+E
SCCR	10kA
EXHAUST CONNECTION	Ø 63 mm
TANK	
VOLUME	385 liter
PUMP CAPACITY	10m ³ /h
HEATER	4,5 kW
FILTERS	2 X 20 inches
SERVICE ACCESS BEHIND TANK	Minimum 500 mm
PLATING POWER	
MAX. VOLTAGE	15 VDC
MAX. CURRENT	30 Amps/cell
CONTROL	
PLC AND 7 INCH TOUCH SCREEN	

Please contact us with any questions or to request.

THE INFORMATION PROVIDED MIGHT BE SUBJECT TO CHANGES.



Pheenix Alpha AB
 Skepptuna Borgen 299
 SE 195 93 Märsta
 +46 (0)8 598 933 00
www.pheenixalpha.com

E-mail info@pheenixalpha.com
Spareparts order handling
order@pheenixalpha.com
Helpdesk/support
helpdesk@pheenixalpha.com

